

SCHEDA TECNICA / TECHNICAL SHEET



FLAT BOX

CARATTERISTICHE GENERALI GENERAL FEATURES

Portata motori / airflow capacity (m³/h):	1300
N° motori / n. motors:	1
Versione / version:	ASPIRANTE SUCTION
Colori / colors:	STRUTTURA ZINCATA - GALVANIZED BODY
Uscita aria / outlet air (mm):	RETTANGOLARE 220x90 - RECTANGULAR 220x90
Voltaggio / voltage (V):	220 - 240
Frequenza / frequency (Hz):	50 - 60
Potenza / power (W):	170
Pressione / pressure (Pa):	450
Rumorosità / noise (dB):	65



CARATTERISTICHE SPECIFICHE SPECIFIC FEATURES

CARATTERISTICHE DEL MOTORE / CHARACTERISTICS OF THE MOTOR

VELOCITA' / VELOCITY	1°	2°	3°	INT.
PORTATA / AIRFLOW CAPACITY (m³/h)	770	1050	1070	1300
PRESSIONE / PRESSURE (Pa)	139	264	347	450
POTENZA / POWER (W)	158	159	160	170
RUMOROSITA' / NOISE (dB)	60	64	65	67

Cavo da 6 metri compreso - 6 meters cable included

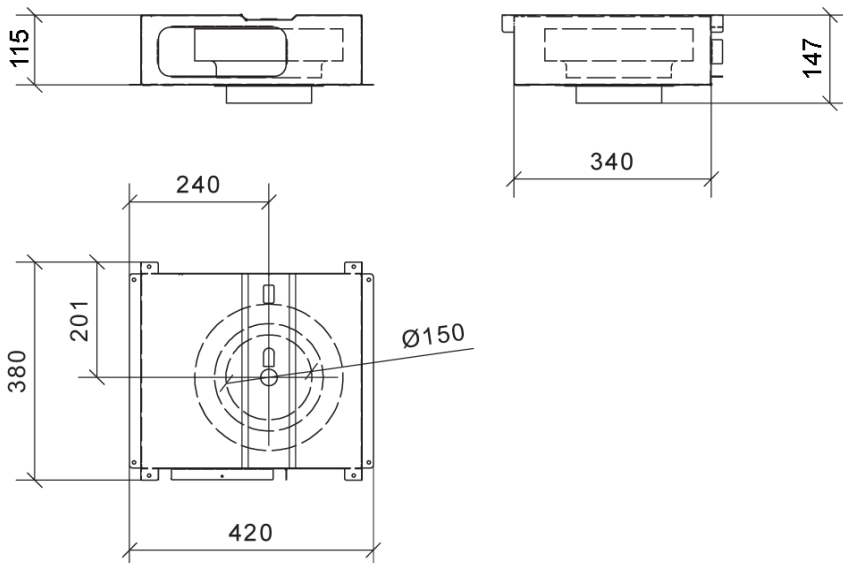

IMBALLO PACKING

MISURE / SIZE (cm)	46 (P) x 42 (L) x 16 (H)
PESO / WEIGHT (kg)	8,0

NOTE NOTES

N.B: La scheda tecnica è indicativa e i dati potrebbero differire al variare dei componenti tecnici